

Customer name:

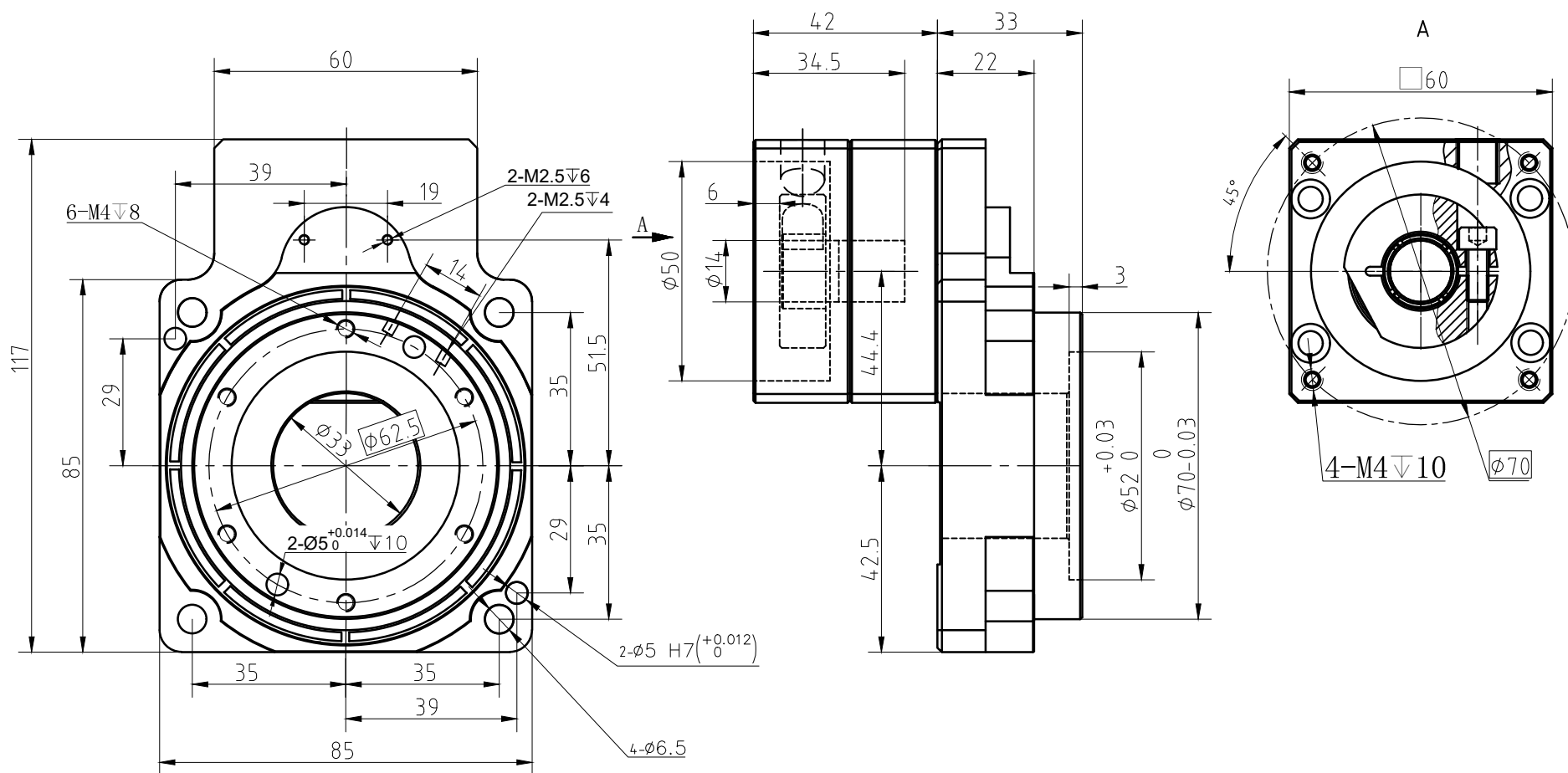
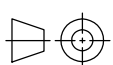

Allowable torque	N.m	16	Bearing type	Cross roller bearing	Sign/Date	Mark	No.	Sign	Date	Precision Planetary Reducer	GMN085	
Allowable disk output speed	rpm	200	Positioning accuracy	arcmin							3	GMN085-10
Allowable axial load	N	500	Repeat positioning accuracy	arcmin	± 10	NOTE	DRAW	APPR	RULE	Shaft Type	Precision	
Allowable moment of inertia load	N.m	28	Concentricity of rotating platform		± 0.01							
Moment of inertia	kg.m ²	21090×10^{-7}	Parallellism of rotating		± 0.015		CHEC	APPR	RULE	GMN085-10		
Precision	H	20000	Parallellism of rotating		± 0.005					Shaft Type		Precision
Weight	kg	1.4	Protection class		IP40	