

Customer Name:

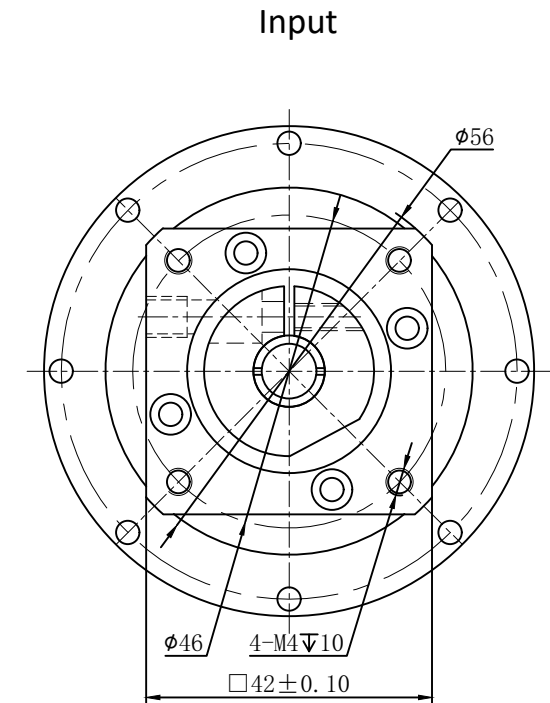
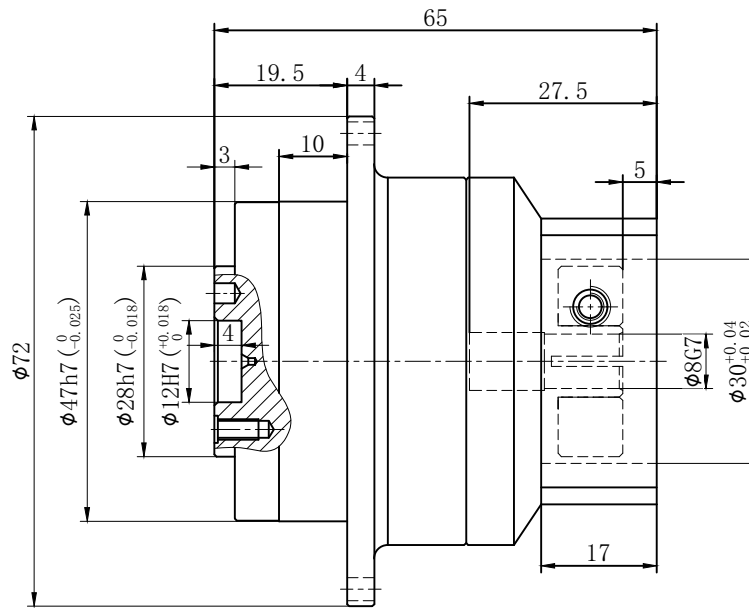
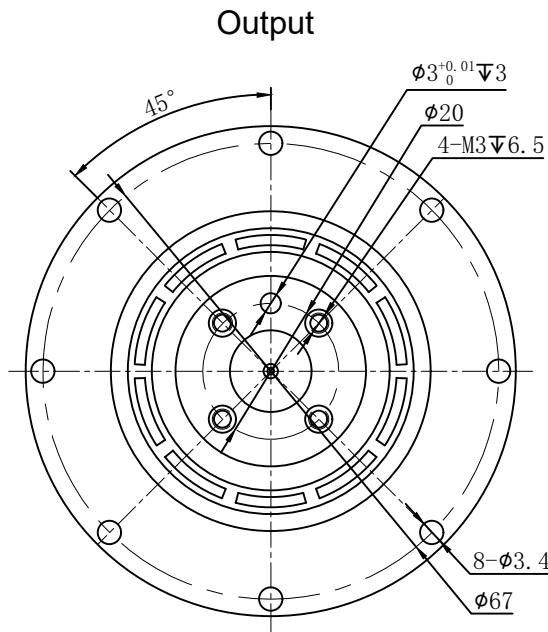

Transmission Ratio	(<u> A </u>):1	Mass Moments Of Inertia	(<u> B </u>)Kg.cm ²
Rated Output Torque	(<u> C </u>)Nm	Max Output Torque	(<u> D </u>)Nm
Rated Input Speed	4000rpm	Max Input Speed	8000rpm
Max Benging Moment	42.5Nm	Max Axial Force	450N
Efficiency	≥ 97%	Operating Temperature	-20~+90°
Mounting Position	Any	Lubrication Method	Synthetic grease
Weight ±3%	0.7Kg	Service Life	30000h
Standard Backlash	--arcmin	Protection Class	IP65
Motor Power	-- KW	Noise Level	56dB
Motor Dimensions			

	4	0.03	19	34.2	Sign/Date					
	5	0.03	20	36						
	7	0.03	19	34.2						
	10	0.03	14	25.2						
Ratio	A	B	C	D		Ratio	A	B	C	D
Note						Precision Planetary Reducer	GD047			
Mark	No.	Sign	Date				GD047-L1			
	DRAW				Shaft Type		Precision			
	CHEC									
	APPR									
	RULE									

Above specifications are for standard reducer and may be subject to change without notice.