

Customer Name:

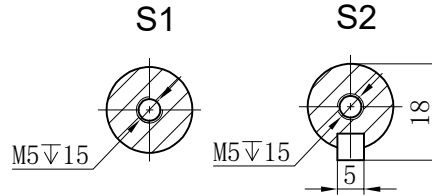
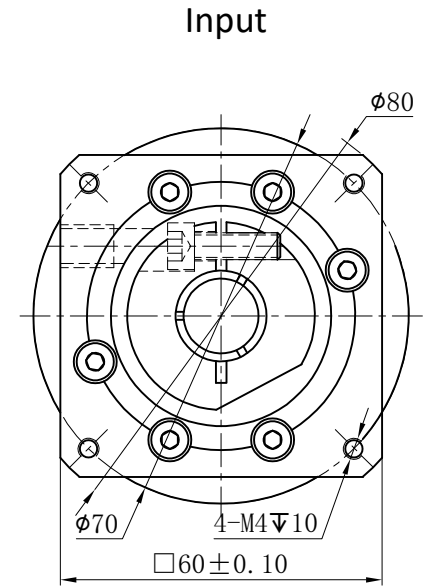
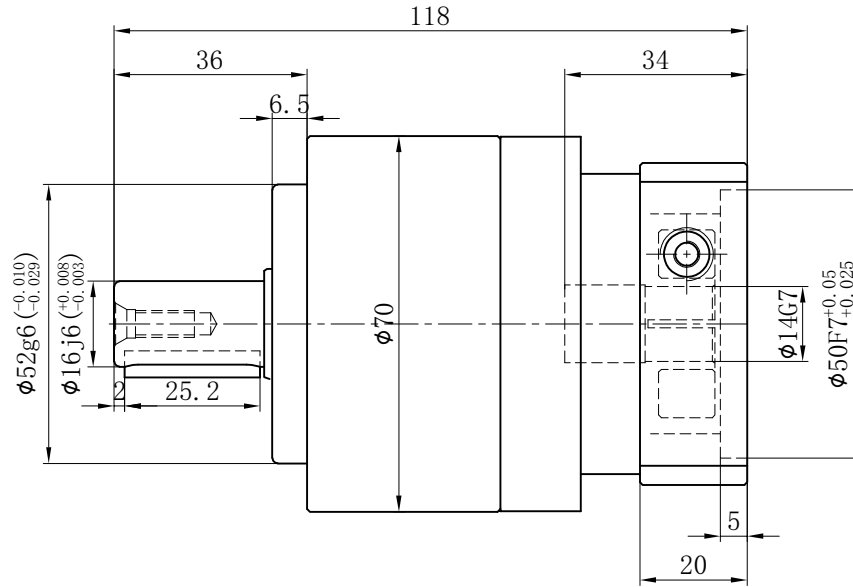
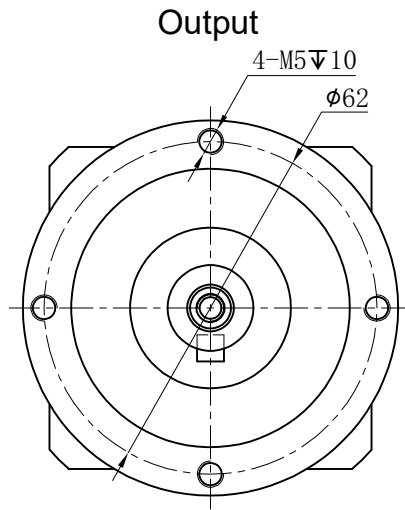

Transmission Ratio	( A ):1	Mass Moments Of Inertia	( B )Kg.cm <sup>2</sup>
Rated Output Torque	( C )Nm	Max Output Torque	( D )Nm
Rated Input Speed	5000rpm	Max Input Speed	10000rpm
Max Radial Force	1530N	Max.axial Force	765N
Efficiency	≥ 97%	Operating Temperature	-20°~+90°
Mounting Position	Any	Lubrication Method	Synthetic grease
Weight ±3%	1.3Kg	Service Life	20000h
Standard Backlash	≤ 5 arcmin	Protection Class	IP65
Motor Power	-- KW	Noise Level	58dB
Motor Dimensions			

	10	0.13	40	72	Sign/Date						
	8	0.13	45	81			7	0.13	50	90	
	6	0.13	55	99			5	0.13	60	108	
	4	0.14	50	90			3	0.16	55	99	
Ratio	A	B	C	D		Ratio	A	B	C	D	
Note						Precision Planetary Reducer	GE070				
	Mark	No.	Sign	Date			GE070-L1				
							Shaft Type	Precision			

Above specifications are for standard reducer and may be subject to change without notice.