

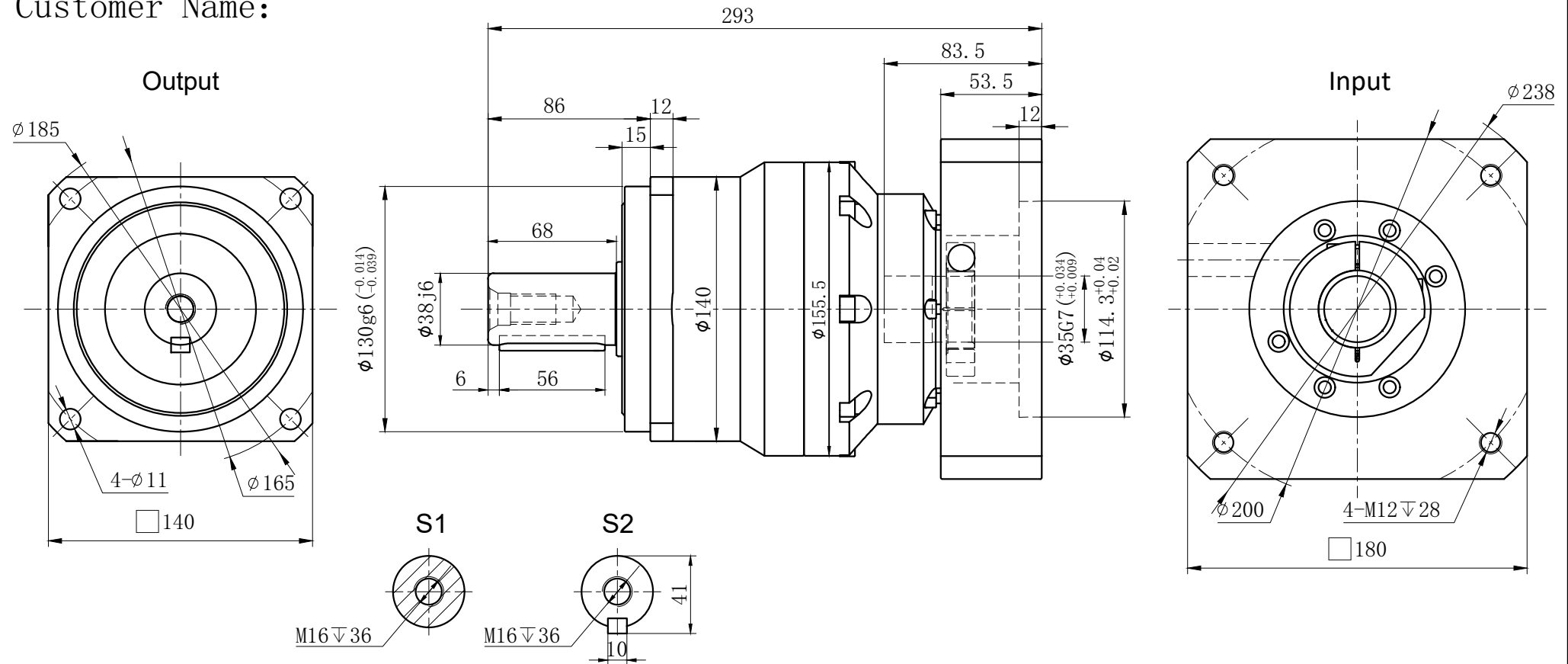

Customer Name:

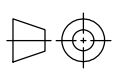

Transmission Ratio	(A):1	Mass Moments Of Inertia	(B)Kg.cm ²											
Rated Output Torque	(C)Nm	Max Output Torque	(D)Nm	20	2.71	535	963	Sign/Date	50	2.54	650	1170		
Rated Input Speed	3000rpm	Max Input Speed	4000rpm	25	2.71	650	1170		60	2.54	600	1080		
Max Radial Force	9400N	Max Axial Force	4700N	30	2.71	600	1080		70	2.54	550	990		
Efficiency	≥ 94%	Operating Temperature	-20°~+90°	35	2.71	550	990		80	2.54	500	900		
Mounting Position	Any	Lubrication Method	Synthetic grease	40	2.71	500	900		100	2.54	445	801		
Weight ±3%	19.8Kg	Service Life	20000h	Ratio	A	B	C	D	Ratio	A	B	C	D	
Standard Backlash	≤ -- arcmin	Protection Class	IP65	Note				Precision Planetary Reducer				GCB140A		
Motor Power	-- KW	Noise Level	65dB	Mark				No.	Sign	Date	GCB140A-L2			
Motor Dimensions												Shaft Type Precision		

Above specifications are for standard reducer and may be subject to change without notice.