

Customer Name:

Output

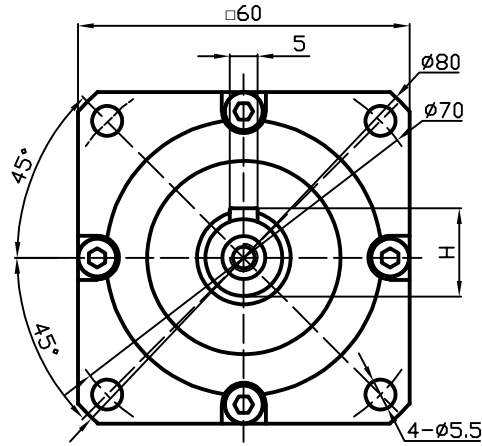

Input

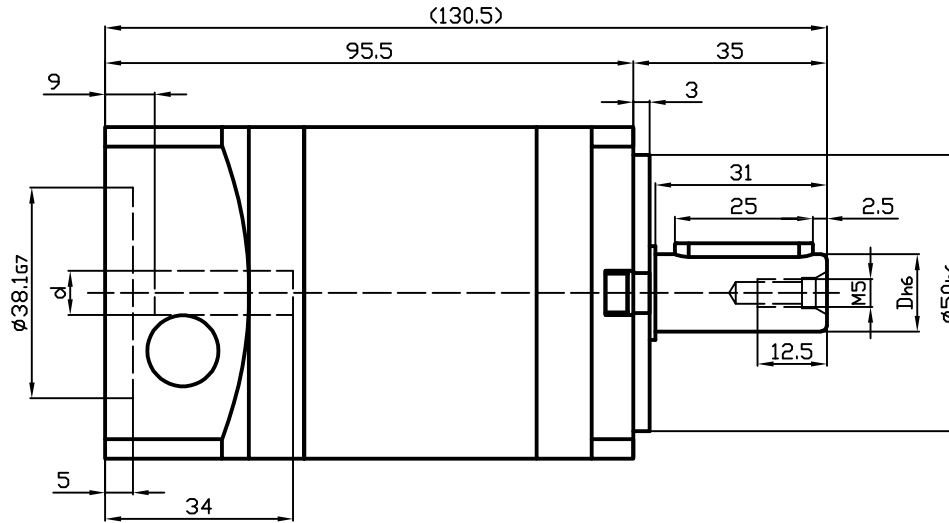
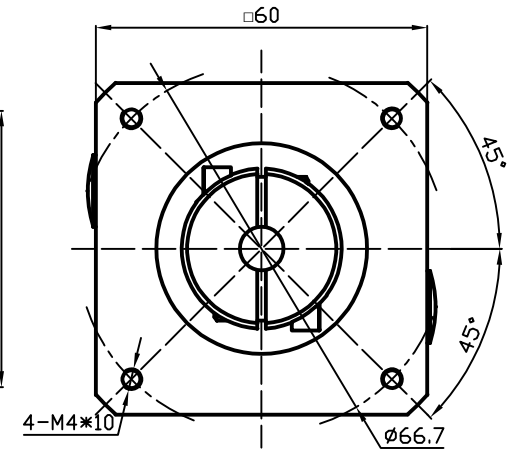

D	H	√	d	√
ø16	18		ø6.35	

Transmission Ratio	( A ):1	Mass Moments Of Inertia	( B )Kg.cm <sup>2</sup>
Rated Output Torque	( C )Nm	Max Output Torque	( D )Nm
Rated Input Speed	3000rpm	Max Input Speed	5000rpm
Max Radial Force	320N	Max.axial Force	280N
Efficiency	≥ 92%	Operating Temperature	-10°~+90°
Mounting Position	Any	Lubrication Method	Synthetic grease
Weight ±3%	1.3Kg	Service Life	20000h
Standard Backlash	≤ 15 arcmin	Protection Class	IP65
Motor Power	-- KW	Noise Level	60dB
Motor Dimensions			

					Sign/Date					
	20	0.58	40	80						
Ratio	A	B	C	D		Ratio	A	B	C	D
Note						Precision Planetary Reducer		GA062		
	Mark	No.	Sign	Date				GA062-L2		
		DRAW						Shaft Type Precision		
		CHEC								
		APPR								
		RULE								

Above specifications are for standard reducer and may be subject to change without notice.